

RELAX

R2T 20

Tweeter

Guy Bonneville

BLAM

DRIVEN BY PASSION

- Hi fidelity 20 mm soft dôme tweeter
- Hi efficiency magnet (N38H neodymium)
- Hi quality special soft dôme material
- Ferrofluid for hi power handling

TECHNICAL SPECIFICATIONS

Component	Tweeter	
Max power	100 W	
Nominal power	10 W	
Impedance	3 Ω	
Freq. Response	2.5 KHz - 25 KHz	
Sensitivity (2,83V/1m)	90 dB	
Magnet	Neodymium	
Magnet size Ø x h	19.5 x 3 mm	0.768" x 0.118"
Total driver displacement	-	-
Weight of one component	0.045 kg	0.099 lb
Voice coil Ø	20 mm	0.803"
Voice coil height	1.3 mm	0.051"
Dome	Silk	



Unit : mm

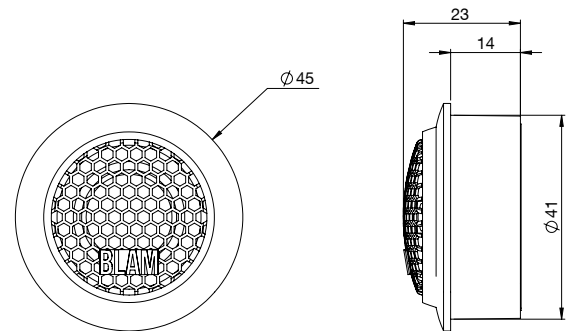

FREQUENCY RESPONSE / IMPEDANCE

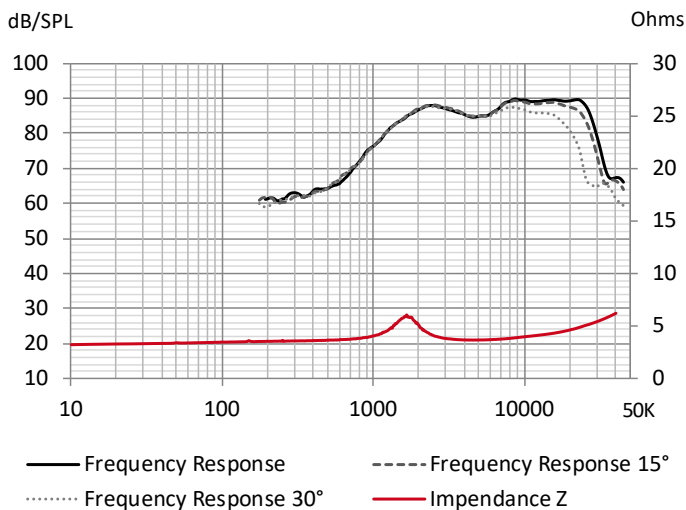

THIELE-SMALL PARAMETERS

effective Ø (d)	22 mm
Sd	3,80 cm ²
Xmax	-
Re	3 Ω
Fs	1651 Hz
Le	-
L2	-
Vas	-
Mms	-
Cms	-
BL	-
Qts	-
Qes	-
Qms	-
Sensitivity (dB/W/m)	85,7 dB

contact@blam-audio.fr
www.facebook.com/blamaudio
www.blam-audio.com