

LIVE

Guy Bonneville

BLAM

DRIVEN BY PASSION

LW 165 P

Woofer

- Woofer 6-1/2" (165 mm)
- Max power 180 W / Nom. power 90 W
- Frequency response 50 Hz - 8 KHz
- Impedance 3 Ohms

Machined cast aluminium basket - Epoxy resin and glass fiber cone - Butyl rubber surround - Long life "Conex" damper - 32 mm (1.26") voice coil with kapton former - 85 mm x 20 mm (3.3" x 0.8") motor assembly - Thick magnetic circuit (5 mm).



TECHNICAL SPECIFICATIONS

Component	Woofer	
Max power	180 W	
Nominal power	90 W	
Impedance	3 Ω	
Freq. Response	50 Hz - 8 KHz	
Sensitivity (2,83V/1m)	91.7 dB	
Magnet	Ferrite	
Magnet size Ø x h	85 x 20 mm	3.346 "x 0.787 "
Total driver displacement	0.35 l	0.012 cf
Weight of one component	1.2 kg	2.646 lb
Voice coil Ø	32 mm	1.260"
Voice coil height	15 mm	0.591"
Cone	Glass fiber	

Unit : mm

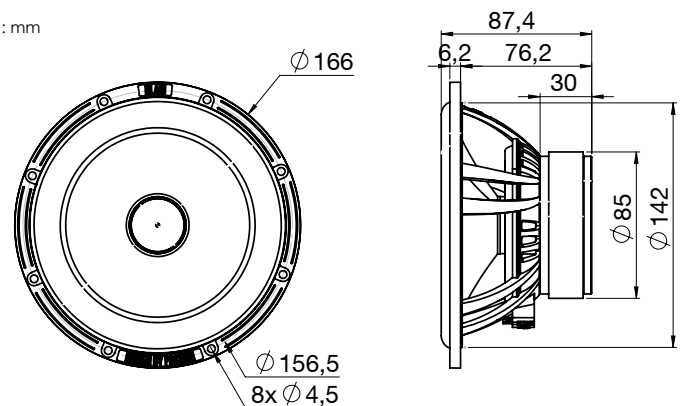

FREQUENCY RESPONSE / IMPEDANCE

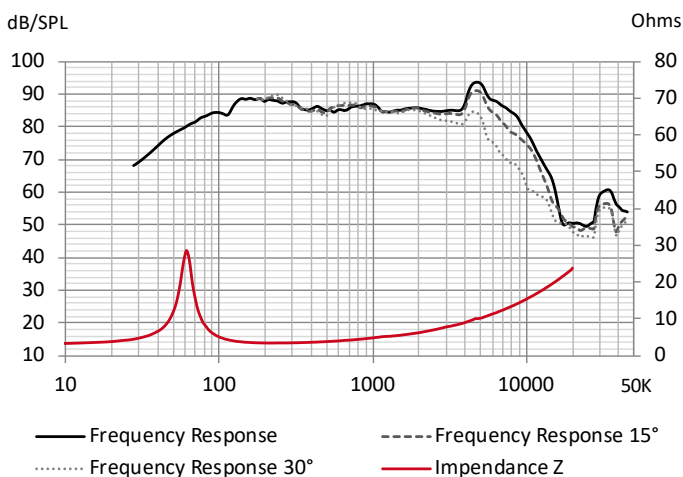

THIELE-SMALL PARAMETERS

effective Ø (d)	130 mm
Sd	132.73 cm ²
Xmax	5 mm
Re	3 Ω
Fs	62.23 Hz
Le	142.67 µH @ 1 kHz
Le	294.07 µH @10 kHz
Vas	10.01 L
Mms	16.16 g
Cms	0.000404 m/N
BL	5.33 Tm
Qts	0.60
Qes	0.67
Qms	5.88
Sensitivity (dB/W/m)	87.4 dB

contact@blam-audio.fr
www.facebook.com/blamaudio

www.blam-audio.com