

RELAX

Guy Bonneville

BLAM

DRIVEN BY PASSION

165 R2

Woofers

- Woofer 6-1/2" (165 mm)
- Max power 150 W / Nom. power 75 W
- Frequency response 60 Hz - 8 KHz
- Sensitivity 95 dB
- Impedance 2 Ohms

TECHNICAL SPECIFICATIONS

Component	Speakers	
Max power	150 W	
Nominal power	75 W	
Impedance	2 Ω	
Freq. Response	60 Hz - 8 KHz	
Sensitivity (2,83V/1m)	95.2 dB	
Magnet	Ferrite	
Magnet size Ø x h	85 x 17 mm	3.346" x 0.669"
Total driver displacement	0,3 l	0.011 cf
Weight of one component	0.92 kg	2.028 lb
Voice coil Ø	25 mm	0.984"
Voice coil height	12 mm	0.472"
Cone	Treated cellulose pulp	



Unit : mm

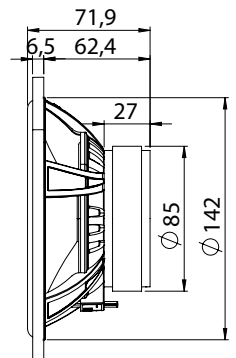
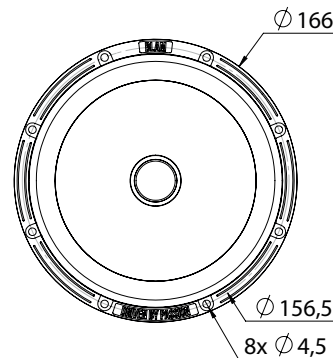

FREQUENCY RESPONSE / IMPEDANCE

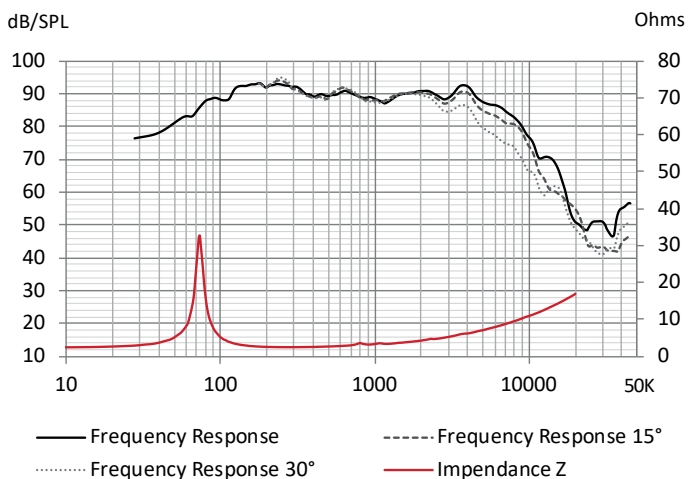

THIELE-SMALL PARAMETERS

effective Ø (d)	130 mm
Sd	132.73 cm ²
Xmax	4 mm
Re	2.18 Ω
Fs	68.97 Hz
Le	110.64 µH @ 1 kHz
L2	274.69 µH @10 kHz
Vas	11.28 L
Mms	11.68 g
Cms	0.000456 m/N
BL	4.15 Tm
Qts	0.60
Qes	0.64
Qms	10.39
Sensitivity (dB/W/m)	89.6 dB

contact@blam-audio.fr

www.facebook.com/blamaudio

www.blam-audio.com